

YARRA DEADLOCK SERIES

Illustrated Fitting Instructions for Yarra Deadlock using:

YARRA VIEW STANDARD OUTER PULL



These instructions describe the steps to install a Yarra View (or Yarra Ridge) deadlock with a Yarra View Standard Outer Pull. Read through all instruction steps before beginning installation. When replacing an old lock, modify the existing installation holes in the door stile and jamb if necessary.

1. Door Preparation

- For optimal installation, ensure the door is rolling smoothly and closing parallel into the jamb by lubricating and adjusting the rollers. Close the door and lightly mark the door stile at the edge of the overlapping jamb.
- Prepare three 9.0mm holes in the door stile as dimensioned below in Figure A. Ensure the holes are straight and free from burrs.

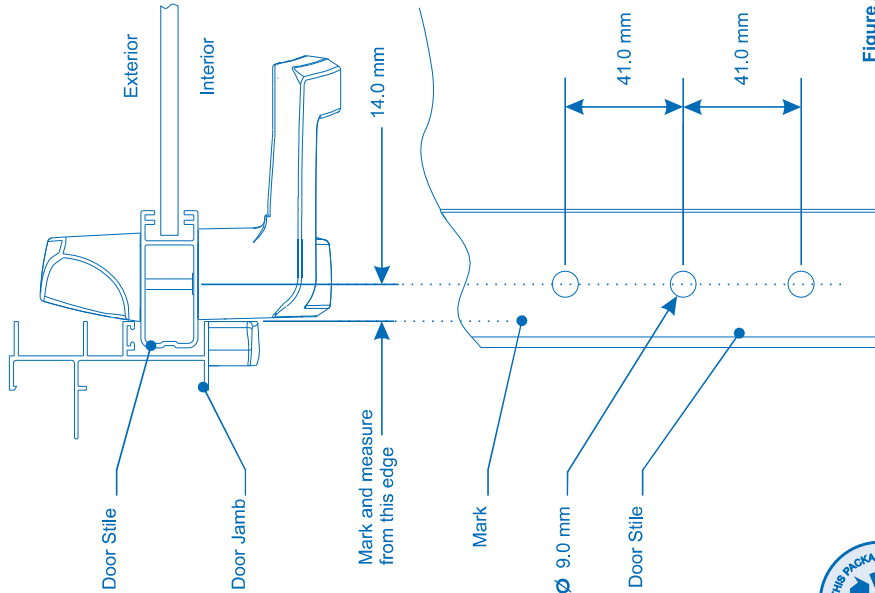

Figure A

2. (optional)

Cylinder installation

- If a cylinder is not being used in the Outer Pull, proceed to STEP 4.
- To remove a Cylinder Plug and install a Keyed Cylinder into the Outer Pull, remove the Retaining Plate and remove the Cylinder Plug. (refer Figure B) The Cylinder Plug can be discarded.
- Use the table in Figure C below to determine the required Spindle length. **NOTE:** If using packer(s), add the total packing thickness to the door thickness, then use this value in the table below.
- Use pliers or a vice to carefully break off the required number of pre-notched portions of the Spindle to suit the door thickness.

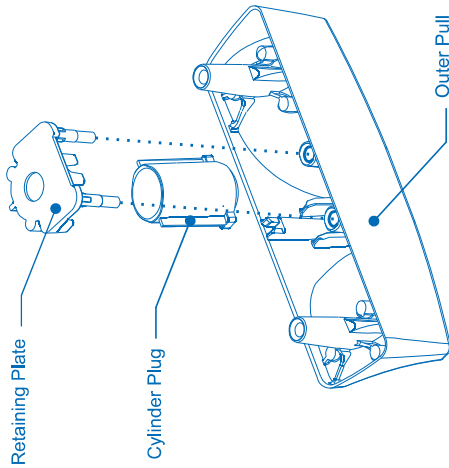

Figure B

Total Width (Door thickness + Packer thickness)

- 46.4 to 40.2mm
- 40.1 to 33.9mm
- 33.8 to 27.6mm
- 27.5 to 21.3mm

Spindle preparation

- Break off '0' portions
- Break off '1' portion
- Break off '2' portions
- Break off '3' portions

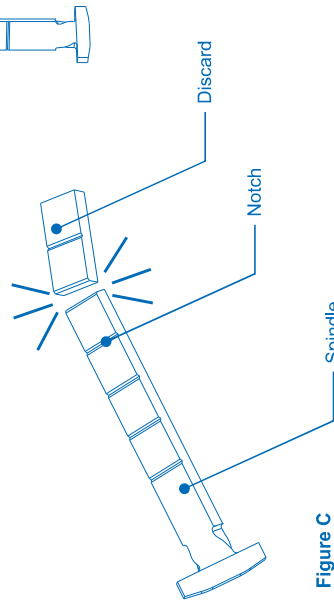

Figure C

3. (optional)

Cylinder installation CONT.

- Install the Keyed Cylinder into the Outer Pull
- Insert the Spindle through the hole in the Retaining plate, and re-assemble the Retaining Plate into the Outer Pull. It may be necessary to rotate the Spindle to find its position between the Drive Pins on the Cylinder.
- Push the Retaining Plate in firmly so it will not come loose while assembling the Outer Pull onto the door.

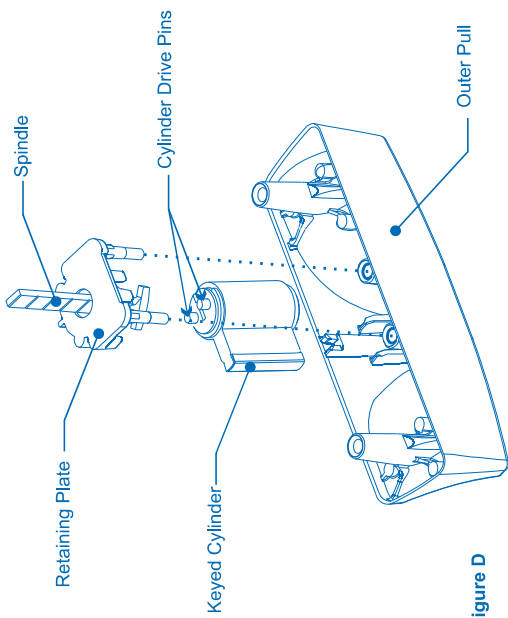

Figure D

4.

Select fixing screws

- Several pairs of Fixing Screws are provided to suit different door thicknesses. Use the table below to identify which are the correct length Fixing Screws. **NOTE:** If using packer(s), add the total packing thickness to the door thickness, then use this value in the table below.

Total Width (Door thickness + Packer thickness)	Screw selection
46.4 to 40.2mm	1 3/4" Fixing Screw
40.1 to 33.9mm	1 1/2" Fixing Screw
33.8 to 27.6mm	1 1/4" Fixing Screw
27.5 to 21.3mm	1" Fixing Screw

Figure E



CARE & MAINTENANCE

Installation

The product must be installed according to the instructions included in the product packaging and the door should be apertured according to the door "cut-out" dimensions and tolerances shown.

Prior to fitting ensure that:

- Doors stored on site are stored in a clean dry area free from cement, lime, paint, acid etc.
- During fitting of the lock ensure that :
 - No metal swarf or other contaminants enter the lock body.
 - The fixing screws do not damage the product finish.

After installation of the door ensure that:

- The door is correctly adjusted with the correct clearances.
- The lock engages the catch plate correctly.
- The door is protected from building fall-out such as wet plaster, mortar, and paint. If the door becomes contaminated:
 - Do not paint the lock body or faceplate.
 - Remove wet plaster, cement, mortar and other droppings immediately, using clean water and a sponge or rag, to avoid permanent staining or scratching of the product finish. If removal is delayed and scraping becomes necessary the surface finish may suffer.

Maintenance

Annually inspect the door to confirm that the door operates with the correct clearances, closes and opens without obstruction. Confirm that the lock beaks engage easily with the catch plate when the door is closed and the lever or key is turned - adjust the door if necessary.

Annually check that when the door is closed, the lock can be locked by key and by the lever.
NB : The lock assembly has been lubricated for life, and should not be disassembled by the user.

Cleaning Powder Coatings

Every six months, powder coated surfaces should be cleaned to protect the finish. However, in areas where pollutants are more prevalent, especially in coastal or industrial regions, cleaning should be carried out every two to three months.

To clean the powder coated surface:

1. Carefully remove any loose deposits with a wet sponge.
2. Use a soft brush (non abrasive) or cloth and a mild household detergent solution to remove dust, salt and other deposits. Do not use steel wool, scrapers, scouring liquids or powders to remove deposits as these permanently scratch the coating surface.
3. Rinse off with clean fresh water.

Cleaning Chrome, Satin Chrome, Gold and Brass Finishes

Plated finishes are susceptible to tarnishing if they come into contact with moisture, wet paint, or water vapour. All plated finishes should be coated with a non-abrasive furniture or car wax immediately after installation. Plated finishes should be regularly wiped with a non-abrasive furniture or car wax, taking care not to scratch any protective finishes that are employed to protect the surface and prevent tarnishing.

MAINTENANCE LOG

In order to protect your warranty, record all maintenance activity in the following log:

Address of Building :	
Name of Door :	
Date	Activity
Signed	

Austral Lock
31 - 33 Alfred Street
Blackburn
VIC 3130 Australia
ph 13 14 18
fax 13 18 14
www.ausloc.com

A Division of
GAINSBOROUGH
Hardware Industries
Limited



Figure G

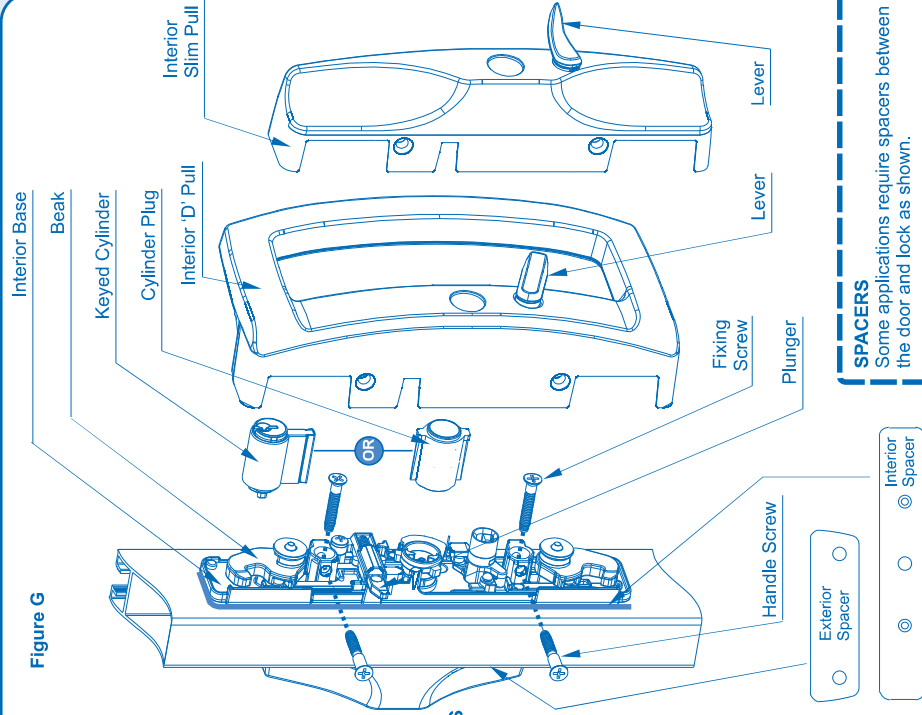

5. Fasten lock to door

1. If the Beaks of the Interior Assembly are extended, use the Lever to retract them.
2. Remove the Handle Screws and lift the Interior Handle off the Interior Base, place them aside.
3. Place the Exterior Assembly onto the exterior face of the door stile. Rotate the protruding Spindle into a vertical position.
4. While placing the Interior Base onto the interior face of the door stile, note the following:
 - Allow the protruding Spindle to enter the receiving slot on the underside of the Interior Base.
 - Locate the bosses on the underside of the Interior Base into the holes in the door stile.
5. Pass the correct length Fixing Screws through the Interior Base and screw firmly into the Exterior Assembly.

NOTE: DO NOT OVER TIGHTEN FIXING SCREWS

6. (optional) Install cylinder

1. To install a Keyed Cylinder into the Interior Assembly, remove and discard the Cylinder Plug from the underside of the Interior Pull.
2. Install the Keyed Cylinder into the Interior Pull as shown in Figure G.

7. Fit Interior Pull

1. Place the Interior Pull over the Interior Base. It may be necessary to rotate the Lever to find its correct orientation. Refit the two Handle Screws.
 2. Depress the Plunger and test the lock operation by operating the Lever and Cylinder Key(s) if applicable.
- NOTE:** Ensure the Beaks are in the retracted position before closing the door.

8. Catch Plate installation

1. To fix the **Catch Assembly** to the front of the jamb, reverse the **Adjustment Screws** from their fully 'screwed-in' position three (3) full turns with the 3.0mm Hex Key. Reverse the Catch Plug Grub Screws with the 2.0mm Hex Key and remove the Catch Plugs using a small screwdriver.
2. Close the door and position the Catch Assembly on the jamb opposite the lock with a 1 to 2mm gap between the lock and Catch Assembly. Mark the centre of the 'front fix' slots and drill the jamb with a 3.5mm drill.



'Front Fix' Catch Screw (3/8")

'Face Fix' Catch Screw (1")

1. Use the two 'Front Fix' Catch Screws provided to fit the Catch Assembly lightly to the jamb. Gently close the door and operate the Lever to test the Beak engagement. Move the Catch Assembly up and down and adjust the Catch Plate in and out to achieve the best fit.
- NOTE:** If required use packers provided to align catch plate assembly with interior handle assembly.

2. Tighten the 'Front Fix' Catch Screws, refit the Catch Plugs and tighten the Catch Plug Grub Screws. Be careful not to over tighten these screws.
3. To fix the Catch Assembly to the face of the reveal, leave the Catch Plugs in place, mark through the 'face fix' slots, and use the 'Face Fix' Catch Screws instead.

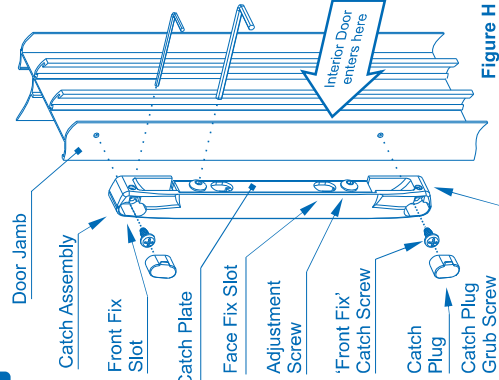

Figure H